

Produktinformation

Saunahaus Mikka Artikel-Nr. 27103



Saunaofen
9 kW Finnisch + Steuergerät Easy
Finnisch

Farbe
Terragrau

Tür
Moderne Saunatür

Bank 1 Tiefe	57 cm
Liegeplätze	3
Tür Breite	83 cm
Tür Schloss	Zylinderschloss mit Handgriff und 3 Schlüsseln
Bank 3 Tiefe	57 cm
Verpackungsmaße mm/Gewicht kg	2370x1160x810x542 2360x1020x230x49,6
Durchgangsmaß Breite	78 cm
Bank 2 Tiefe	57 cm
Innenmaß Tiefe Gesamt	184 cm
Dachtiefe	227 cm
Einstiegsart	Eckeinstieg
Tür Öffnungsrichtung	links
Tür Höhe	177 cm
Ofenschutz Tiefe	51 cm
Material	Nordische Fichte
Türart	Einflügeltür
Grundfläche	3,6 m ²
Außenmaß Breite	231 cm
Spiegelbar	nein
Innenmaß Breite Sauna	219 cm
Außenmaß Tiefe	196 cm
Dachbreite	262 cm
Umbauter Raum	8,9 m ³
Ofenschutz Breite	60 cm
Sitzplätze	5
Ofenschutz Material	nordische Fichte
Bank Material	Espe
Ofenschutz Höhe	80 cm
Firsthöhe	226 cm
Bedarf Dachbahn	2 Rollen
Bauweise	Steck-Schraub-System
Wandstärke	38 mm
Fußbodentyp	Massivholz
Durchgangsmaß Höhe	175 cm
Saunadach Dämmung	Mineralwolle
Innenmaß Breite Gesamt	219 cm
Innenmaß Höhe Gesamt	190 cm
Innenmaß Höhe Sauna	190 cm
Saunadach Bauweise	vormontierte Elemente
Seitenhöhe	210 cm
Anzahl Bänke	3 Stk.
Ofensteuerung	extern Easy Finnisch
Innenmaß Tiefe Sauna	184 cm
Typ Ofen	9 KW externe Steuerung
Farbe	Terragrau

Tür
Dachfläche

Moderne Saunatür
5,5 m²

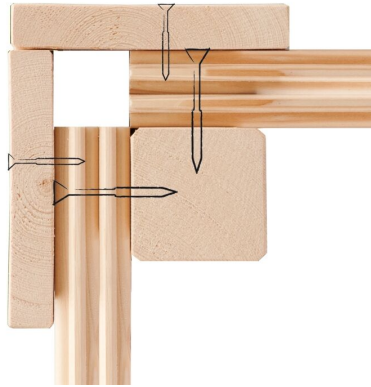

KDI UNTERLEGER



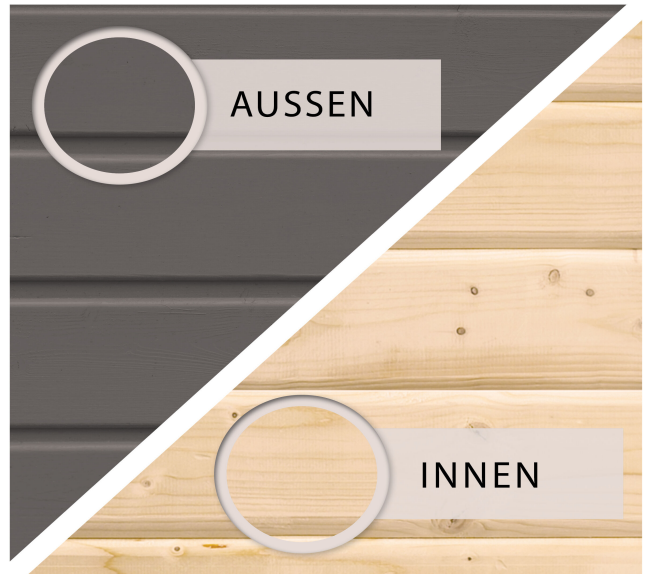
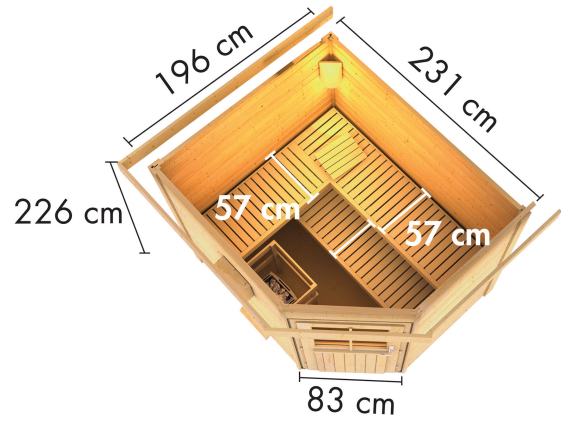

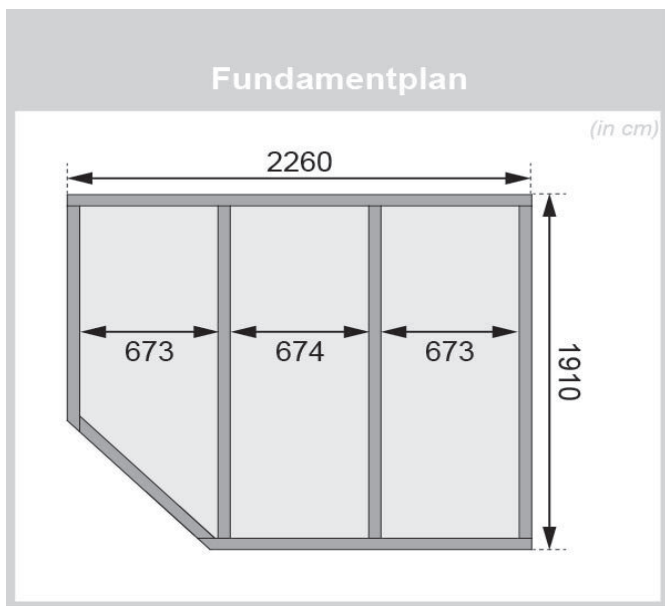

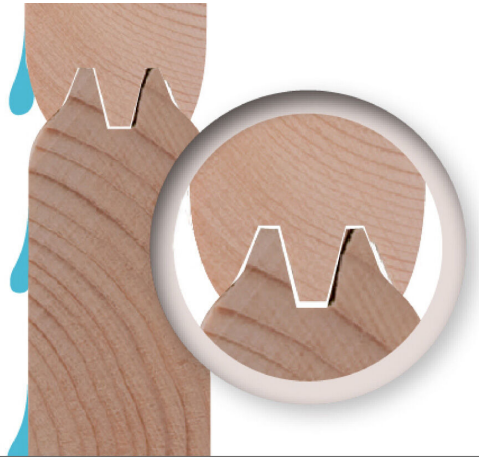

38mm PROFILE



Doppelte Nut und Feder-Verbindung bietet perfekten Sitz durch modernste Frästechnik.

38mm Holzbohlen aus nordischem Fichtenholz gehobelt

